

# ALFA1035H-2

<b>Product Family</b>	Ovens
<b>Subfamily</b>	4 trays 600x400 mm o GN1/1
<b>Oven type</b>	Fan with humidification
<b>Oven controls</b>	Mechanical
<b>Tray capacity</b>	10 trays 600x400 mm - GN1/1
<b>Default power supply</b>	400 V 3N~ / 23A / 16 kW / 50-60 Hz
<b>Steam technology</b>	Direct
<b>App for recipe development and upload</b>	Not available
<b>Maximum depth with open door</b>	1536 mm
<b>Adjustable feet</b>	Yes
<b>Net weight (kg)</b>	102,000 kg
<b>Product dimensions WxDxH</b>	798x772x1100 mm

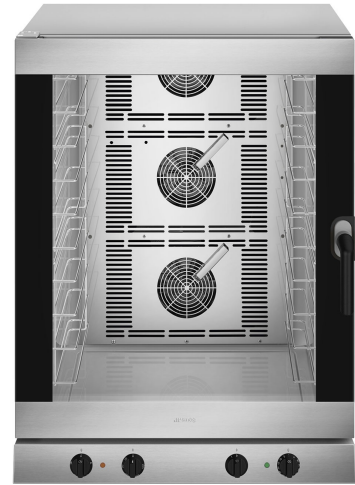

## Target

<b>Potential users</b>	Bakery/Pastry making; Industrial pastry & bakery test kitchen; Butcher's shops	<b>Suggested for</b>	Bars/Cafes
------------------------	---	----------------------	------------

## Aesthetics

<b>Colour</b>	Stainless steel	<b>Front panel Logo</b>	Yes Smeg printed
<b>Door with stainless steel strip</b>	Yes		

## Controls

<b>Adjustable timer</b>	1-60 minutes + continuous	<b>Adjustable chimney</b>	Manual
-------------------------	---------------------------	---------------------------	--------

## Programs / Functions

### Cooking functions



Fan assisted



Fan assisted with humidification

## Options

Right hand hinge	ALFA1035HR-2	Condense hood	K4610X
Right hand hinge	ALFA1035EHR		

## Construction

Oven material	Stainless steel/glass/plastics	Humidification system on each fan	Yes
Cavity dimensions (WxDxH)	672x437x854mm	Steam assisted levels	Manual
Gross volume	616x431x340mm	Exhaust exit	Back
Net volume	616x431x340mm	Time adjustment	Electromechanical timer
Internal net volume	199,1 lt	Temperature range	50-270°C
Cavity material	Stainless steel	End of cooking alarm	Yes
No. of shelves	10	Orange light indicator when t° achieved	Yes
Tray support frame	Chrome	Green light indicator when time achieved	Yes
Distance between shelves	77 mm	Heating element interruption with open door	Yes
Door construction	Yes	Manual safety thermostat reset	Yes
Door opening	Lateral	Removable deflector	Yes
Handle type	New ergonomics	No. of lights	3 Halogen lights
Inner glass	Openable	Light power	40 W
Fan type and number	3 contrarotating fans with time direction reversal	Water connection	Yes
Fan motor power	180W	Power cable length	170 cm
Fan speed	Single speed	Back panel	Galvanized
Max motor speed (rpm)	2	IPX protection	Scheduled start H/12

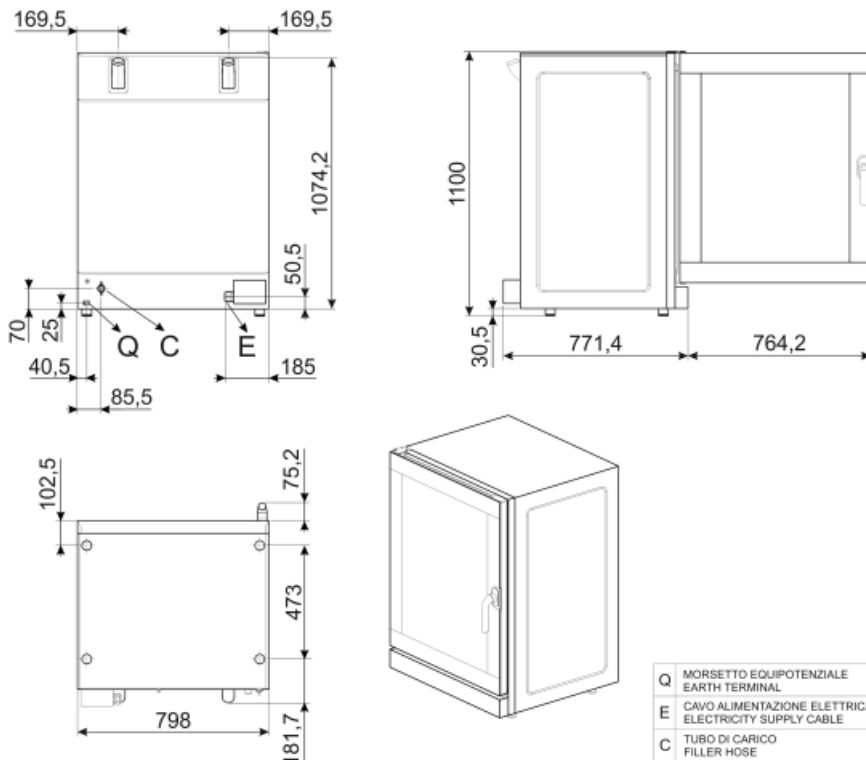

## Not included accessories



**3805**  
Flat chrome-plated wire grid



**3927**  
Air flow reducer kit

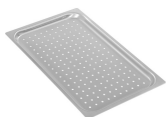

**TF11XH2**  
Perforated aluminium GN1/1 tray for Galileo professional

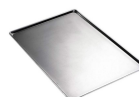

**3743**  
Flat aluminium tray

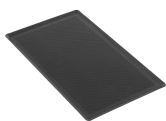

**TMF11TH2**  
GN 1/1 non-sticking microperforated tray



**T11XH20**  
2cm height aluminium GN1/1 tray for Galileo professional



**T11XH65**  
6,5cm height aluminium GN1/1 tray for Galileo professional



**T11TH20**  
2cm height GN1/1 non-stick tray for Galileo professional



**3751**  
Flat perforated aluminium tray

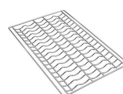

**3810**  
Corrugated grid for baguettes

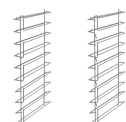

**RGN11-1035-2**



**T8S11T**  
8 holes GN 1/1 non-sticking tray for Galileo professional



**T11TH40**  
4cm height GN1/1 non-stick tray for Galileo professional

## Alternative products

---



ALFA1035HR-2

## Symbols glossary

---



Fan forced



Fan with humidification