

Contents

1 Instructions	30
1.1 General safety instructions	30
1.2 Identification plate	33
1.3 Manufacturer liability	33
1.4 Appliance purpose	33
1.5 Disposal	33
1.6 This user manual	34
1.7 How to read the user manual	34
2 Description	35
2.1 General Description	35
2.2 Control panel	36
2.3 Other parts	37
3 Use	38
3.1 First use	38
3.2 Using the oven	38
3.3 Cooking advice	40
4 Cleaning and maintenance	41
4.1 Cleaning the appliance	41
4.2 Cleaning the door	41
4.3 Removing the internal glass pane	43
4.4 Cleaning the oven cavity	46
4.5 Extraordinary maintenance	47
4.6 If the appliance is not working properly	49
5 Installation	50
5.1 Electrical connection	50
5.2 Water connection	52
5.3 Positioning	52

TRANSLATION OF THE ORIGINAL INSTRUCTIONS

We advise you to read this manual carefully, which contains all the instructions for maintaining the appliance's aesthetic and functional qualities.

For further information on the product: www.smegfoodservice.com



Instructions

1 Instructions

1.1 General safety instructions

Risk of personal injury

- During use the appliance and its accessible parts become very hot.
- Never touch the heating elements during use.
- Keep children under the age of eight at a safe distance unless they are constantly supervised.
- Children must not play with the appliance.
- This appliance may be used by children aged at least 8 and by people of reduced physical, sensory or mental capacity, or lacking in experience in the use of electrical appliances, provided that they are supervised or instructed by adults who are responsible for their safety.
- Never try to put out a fire or flames with water: Turn off the appliance and smother the flames with a fire blanket or other appropriate cover.
- Keep the oven door closed during cooking.
- Protect your hands by wearing oven gloves when moving food inside the oven.
- Do not touch the heating elements inside the oven.
- Do not pour water directly onto very hot trays.
- Do not allow children to approach the appliance when it is in operation.
- If you need to move food or at the end of cooking, open the door 5 cm for a few seconds, let the steam come out, then open it fully.
- Cleaning and maintenance must not be carried out by unsupervised children.
- Do not spray any spray products near the appliance.
- Do not use or leave flammable materials near the appliance.
- Do not use plastic cookware or containers when cooking food.
- Do not put sealed tins or containers in the oven.



- Do not leave the appliance unattended during cooking operations where fats or oils could be released.
- Remove all trays and racks which are not required during cooking.
- Do not insert pointed metal objects (cutlery or utensils) into the slots in the appliance.
- Switch off the appliance immediately after use.
- Do not modify this appliance.
- Have qualified personnel carry out installation and assistance interventions according to the standards in force.
- Do not try to repair the appliance yourself or without the intervention of a qualified technician.
- If the power supply cable is damaged, it must be replaced by the manufacturer, by Technical Support or other qualified personnel in order to ensure a hazard is not created.
- Do not place containers with liquids or food products which can melt during cooking on the upper shelves which are not visible.
- The floor next to the appliance could be very slippery. Be very careful.
- The terminal indicated by the  symbol connects components that are normally earthed. Connect the appliances appropriately using this terminal in order to make sure that they are equipotential.
- Have the electrical connection performed by authorised technical personnel.
- The appliance must be connected to earth in compliance with electrical system safety standards.
- Disconnect the mains power supply.
- Do not pull the cable to remove the plug.
- Use H07RN-F cables withstanding a temperature of at least 75 °C.
- The tightening torque of the screws of the terminal supply wires must be 1.5 - 2 Nm.



Instructions

Risk of damaging the appliance

- Racks and trays have to be inserted into the side guides until they come to a complete stop. The mechanical safety locks that prevent the rack from being taken out accidentally must face downwards and towards the back of the appliance.
- Use wooden or plastic utensils.
- Do not seat on the appliance.
- Do not use abrasive or corrosive detergents (e.g. scouring powders, stain removers and metallic sponges) on glass parts.
- Do not use steam jets to clean the appliance.
- Do not obstruct ventilation openings and heat dispersal slots.
- Never leave the appliance unattended during cooking operations where fats or oils could be released.
- Never leave objects on the cooking surface.
- Do not use the appliance to heat rooms for any reason.
- Remove any food residues or large spills from previous cooking operations from the inside of the oven.
- Do not cover the bottom of the oven cavity with aluminium or tin foil sheets.
- If you wish to use greaseproof paper, place it so that it will not interfere with the hot air circulation inside the oven.
- Do not place pans or trays directly on the bottom of the oven cavity.
- Do not pour water directly onto very hot trays.
- Do not use steam jets to clean the appliance.
- Do not use cleaning products containing chlorine, ammonia or bleach on parts made of steel or that have metallic surface finishes (e.g. anodizing, nickel- or chromium-plating).
- Do not use abrasive or corrosive detergents (e.g. scouring powders, stain removers and metallic sponges) on glass parts.
- Do not use rough or abrasive materials or sharp metal scrapers.
- Shut off the power supply during cleaning and maintenance procedures.



For this appliance

- Do not rest any weight or sit on the open door of the appliance.
- Take care that no objects are stuck in the doors.
- Have the condition of the components checked regularly by Technical Support.
- The A-weighted sound pressure level is below 70 dB(A).

1.2 Identification plate

- The identification plate bears the technical data, serial number and brand name of the appliance. Do not remove the identification plate for any reason.

1.3 Manufacturer liability

The manufacturer declines all liability for damage to persons or property caused by:

- Use of the appliance other than that specified;
- Failure to comply with the instructions in the user manual
- Tampering with any part of the appliance
- The use of non-original spare parts.

1.4 Appliance purpose

This appliance is intended for cooking food in the professional catering environment. Every other use is considered improper.

This appliance must not be used by people (including children) of reduced physical or mental capacity, or lacking in experience in the use of electrical appliances, unless they are supervised or instructed by adults who are responsible for their safety.

1.5 Disposal



This appliance must be disposed of separately from other waste (Directives 2002/95/EC, 2002/96/EC, 2003/108/EC). The appliance does not contain substances in quantities sufficient to be considered hazardous to health and the environment, in accordance with current European directives.

To dispose of the appliance:

- Cut the power supply cable and remove it along with the plug.



**Power voltage
Danger of electrocution**

- Disconnect the mains power supply.
- Disconnect the appliance.



Instructions

- Deliver the appliance to the appropriate recycling centre for electrical and electronic equipment waste, or return it to the retailer when purchasing an equivalent product, on a one for one basis.

Our appliances are packaged in non-polluting and recyclable materials.

- Deliver the packing materials to the appropriate recycling centre.



Plastic packaging Danger of suffocation

- Do not leave the packaging or any part of it unattended.
- Do not let children play with the plastic bags.

1.6 This user manual

This user manual is an integral part of the appliance and must therefore be kept in its entirety and within the user's reach for the whole working life of the appliance.

Read this user manual carefully before using the appliance.

1.7 How to read the user manual

This user manual uses the following reading conventions:

Instructions



General information on this user manual, on safety and final disposal.

Description



Description of the appliance and its accessories.

Use



Information on the use of the appliance and its accessories, cooking advice.

Cleaning and maintenance



Information for proper cleaning and maintenance of the appliance.

Installation



Information for the qualified technician: Installation, operation and inspection.



Safety instructions



Information



Advice

1. Sequence of instructions for use.

- Standalone instruction.



2 Description

2.1 General Description

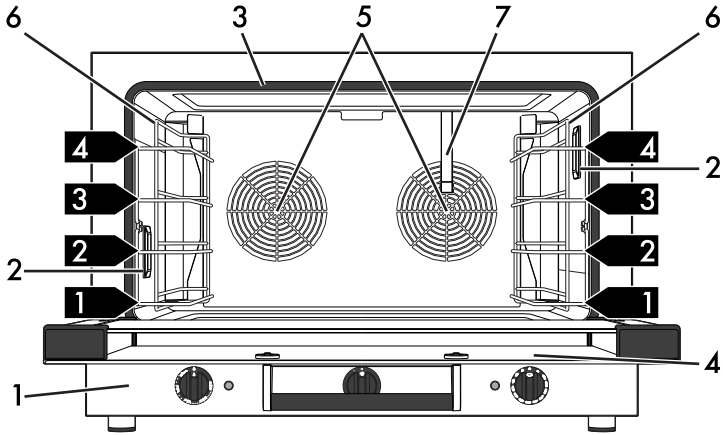

Tilting door

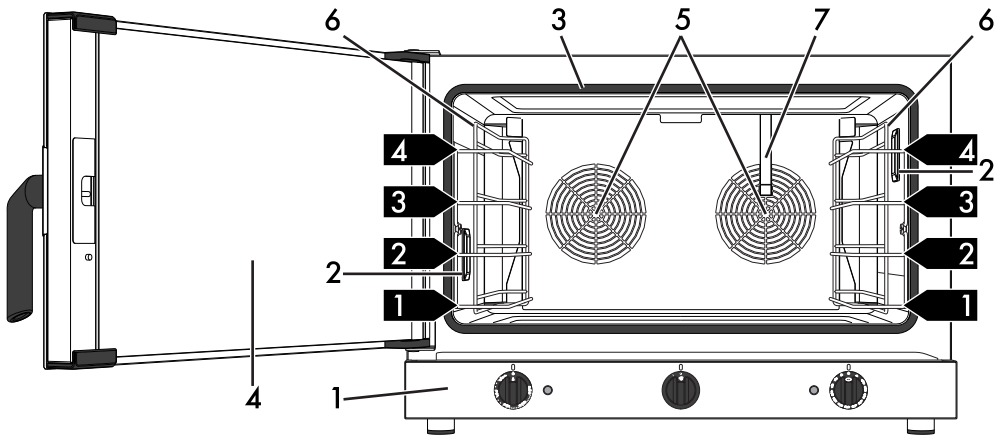

Swing door

- 1 Control panel
- 2 Oven light
- 3 Seal
- 4 Door

- 5 Fan
- 6 Tray support frames
- 7 Water intake line
- 1,2,3** Frame shelf



Description

2.2 Control panel

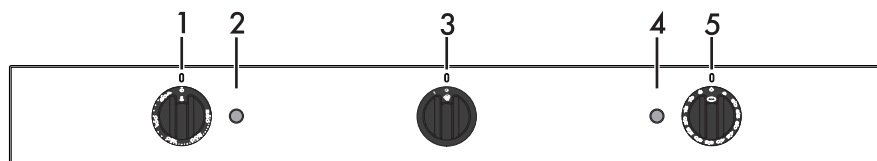

1 Temperature knob

This knob allows you to select the cooking temperature.

Turn the knob clockwise to the required value, between the minimum and maximum setting.

2 Thermostat indicator light

When the indicator light is fixed, it indicates that the oven is heating up to reach the set temperature. Once the temperature has been reached, the indicator light comes on and goes off to indicate that the temperature is being kept constant.

3 Humidification knob

Dispenses steam to improve cooking. Turn the knob clockwise to the **1** position. Steam will be dispensed until the knob is released.

5 Timer indicator light

When off, it indicates the beginning of timed cooking. When on, it indicates that timed cooking has finished.

6 Timer knob

This knob allows you to select manual or timed cooking. Turn the knob to the symbol  for manual cooking or to the numbers to select the minutes of cooking. Once the countdown has finished, the knob will automatically return to the "0" position, the oven switches off and a beep sounds to indicate the end of cooking.



For humidified cooking, place the function/temperature knob at a temperature greater than **150°C**.



2.3 Other parts

Shelves

The appliance features shelves to position trays and racks at different heights. The insertion heights are indicated from the bottom upwards (see 2.1 General Description).

Internal ventilation

When the door is opened, oven ventilation is automatically switched off (together with the heating elements); it then resumes as soon as the door is closed.

Interior lighting

The oven light comes on when the appliance is running or when the door is opened.

Safety thermostat

The appliance is equipped with a safety device that triggers in case of serious malfunction.

Only for the installer/technical support:

1. Unscrew the protective cover for the thermostat with the dedicated tool.
2. To reset the safety thermostat, press the button on the back.

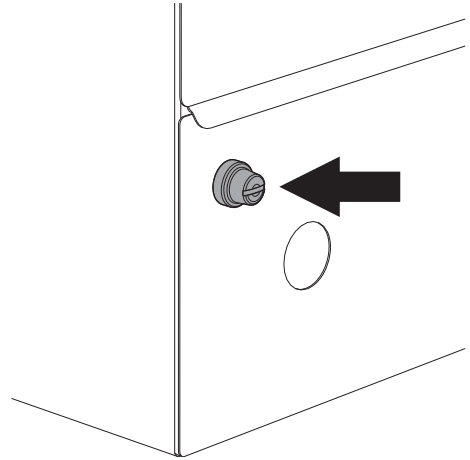

Contact Technical Support immediately after the safety device has triggered to check if there are any faults.

Optional accessories

Original optional accessories can be requested from Authorised Assistance Centres. Use only original accessories supplied by the manufacturer.



3 Use

3.1 First use

1. Remove any protective film from the outside or inside of the appliance, including accessories.
2. Remove any labels (apart from the technical data plate) from the accessories and from the oven cavity.
3. Remove and wash all the appliance accessories (if fitted) (see 4 Cleaning and maintenance).
4. Heat the empty oven at the maximum temperature to burn off any residues left by the manufacturing process.

3.2 Using the oven



The oven is designed for a maximum load of 12 kg.

Switching on the oven

To switch the oven on:

1. Select the temperature using the temperature knob.
2. Select the cooking time (up to 60'), or set manual cooking  using the timer knob.

Opening and closing the door (only on swing door models)

The appliance is equipped with a swing door.

To prevent any steam in the oven from creating problems, the oven door has been equipped with a two-stage opening device.

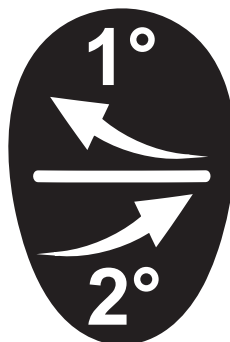

To open the door:

1. Turn the handle completely to the left and pull;

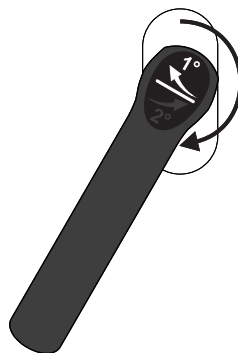



2. Then turn it to the right to fully open the door.



3. To close the door again, push it until you hear a mechanical "click".



The swing door does not lock in the open position and may tend to swing close again. During use, pay attention not to come into contact with the internal glass pane to prevent burns.



Over time the swing door might become more difficult to open and close. Grease the hinges.

Cooking modes



Defrost

The movement of air at room temperature causes frozen food to defrost quickly. This type of rapid defrosting is ideal as the taste and appearance of the de-frozen food, whether previously deep-frozen or frozen in the freezer, remain unaltered.



Normal cooking

Using the fan and the circulaire heating element (incorporated in the rear of the oven) allows you to cook different foods on several levels. Hot air circulation ensures instant and even distribution of heat.

50-250
°C



Cooking with humidification

Oven humidification does not take place at temperatures lower than 150°C: lower temperatures cause condensation and dripping.



150-250
°C

Therefore, turn the temperature knob to a value higher than 150°C and wait until the (orange) thermostat indicator light switches off before starting the oven humidification cycle.



It is not recommended to keep the humidification knob turned for more than 3 seconds at a time.



3.3 Cooking advice

General advice

- Use a fan assisted function to achieve consistent cooking at several levels.
- It is not possible to shorten cooking times by increasing the temperature (the food could be overcooked on the outside and undercooked on the inside).

Advice for cooking meat

- Cooking times vary according to the thickness and quality of the food and to consumer taste.
- Use a meat thermometer when roasting meat, or simply press on the roast with a spoon. If it is hard, it is ready; If not, it needs another few minutes cooking.

Advice for cooking with the Grill

- Meat can be grilled even when it is put into the cold oven or into the preheated oven if you wish to change the effect of the cooking.
- We recommend placing the food at the centre of the rack.
- With the Grill function, we recommend that you turn the temperature knob to the maximum value to optimise cooking.

Advice for cooking desserts/pastries and biscuits

- Use dark metal moulds: They help to absorb the heat better.

- The temperature and the cooking time depend on the quality and consistency of the dough.
- To check whether the dessert is cooked right through: At the end of the cooking time, put a toothpick into the highest point of the dessert. If the dough does not stick to the toothpick, the dessert is cooked.
- If the dessert collapses when it comes out of the oven, on the next occasion reduce the set temperature by about 10°C, selecting a longer cooking time if necessary.

Advice for defrosting

- Place frozen foods without their packaging in a lidless container on the first shelf of the oven.
- Avoid overlapping the food.
- To defrost meat, use the rack placed on the second level and a tray on the first level. This way, the liquid from the defrosting food drains away from the food.

To save energy

- Stop cooking a few minutes before the time normally used. Cooking will continue for the remaining minutes with the heat which has accumulated inside the oven.
- Reduce any opening of the door to a minimum to avoid heat dispersal.
- Keep the inside of the appliance clean at all times.



4 Cleaning and maintenance

4.1 Cleaning the appliance



We recommend the use of cleaning products distributed by the manufacturer.

Recommendations for cleaning the appliance

To keep the surfaces in good condition, they should be cleaned regularly after use. Let them cool first.

Ordinary daily cleaning

Always use only specific products that do not contain abrasives or chlorine-based acids.

Pour the product onto a damp cloth and wipe the surface, rinse thoroughly and dry with a soft cloth or a microfibre cloth.

Food stains or residues

Do not use steel sponges and sharp scrapers as they will damage the surface. Use normal, non-abrasive products and a wooden or plastic tool, if necessary. Rinse thoroughly and dry with a soft cloth or a microfibre cloth.

4.2 Cleaning the door

The glass in the door should always be kept thoroughly clean. Use absorbent kitchen roll. In case of stubborn dirt, wash with a damp sponge and an ordinary detergent.



We recommend the use of cleaning products distributed by the manufacturer.

Removing the door (only on tilting door models)

For easier cleaning it is recommended to remove the door and place it on a tea towel.

To remove the door proceed as follows:

1. Open the door.
2. Pull the upper caps to remove them.

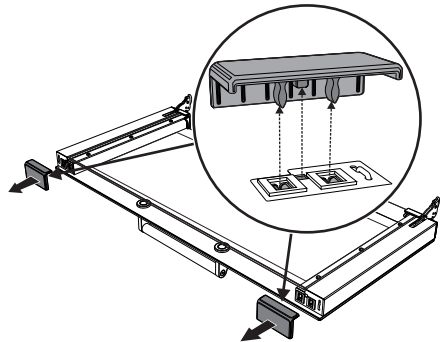

3. Extract the retaining clips on the door frame, underneath the caps which you have just removed.



Cleaning and maintenance

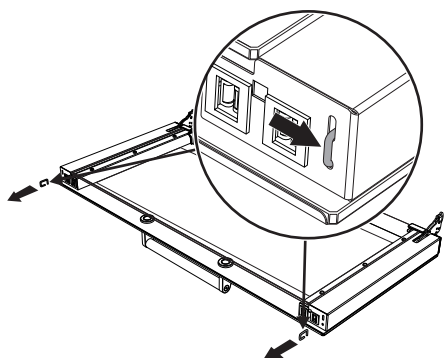

4. Position the retaining clips in the holes in the hinges in order to prevent the door being closed accidentally.

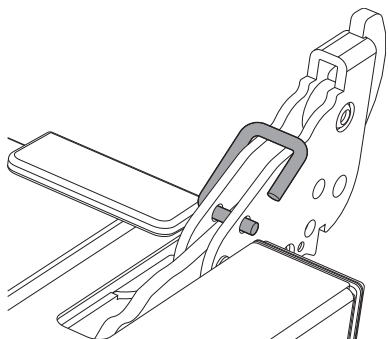

5. Grasp the door on both sides with both hands, lift it, forming an angle of around 30°, and remove it.

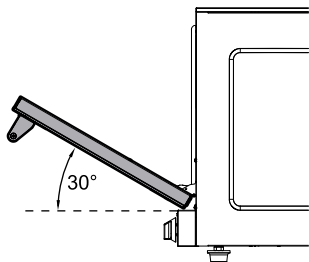

To reinstall the door proceed as follows:

6. Insert the hinges in the corresponding slots in the oven, making sure that grooved sections **A** are resting completely in the slots.

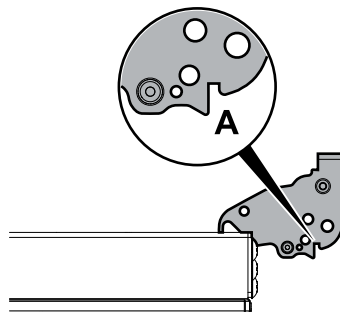

7. Lower the door.
8. Remove the retaining clips from the hinges and position them in their seats on the door frame.
9. Replace the caps at the top of the door.

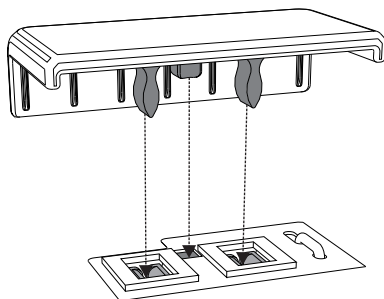

10. Close the door.



4.3 Removing the internal glass pane

Tilting door models



Improper use
Crushing hazard

- Ensure you have locked the door hinges before removing the glass panes.



For easier cleaning, we suggest removing the door.

The internal glass panes of the door can be removed as follows:

1. Open the door.
2. Pull the upper caps to remove them.

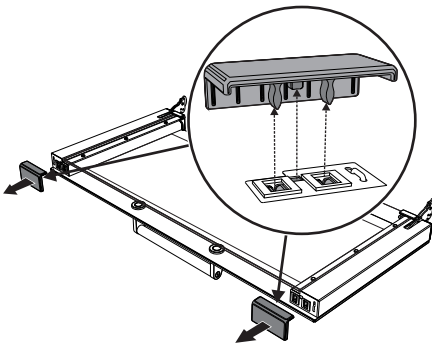

3. Extract the retaining clips on the door frame, underneath the caps which you have just removed.

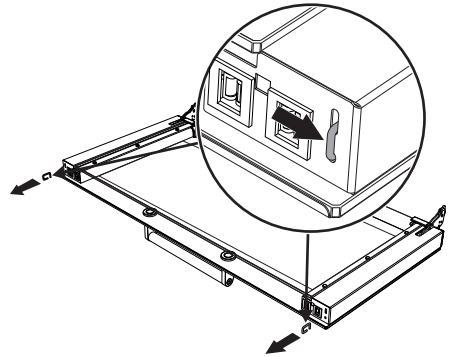

4. Position the retaining clips in the holes in the hinges in order to prevent the door being closed accidentally.

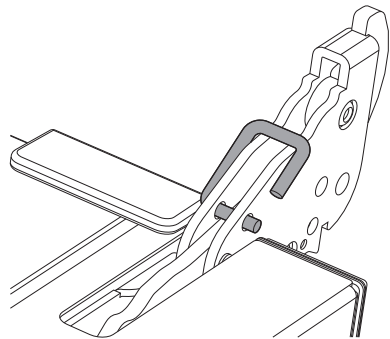



Cleaning and maintenance

5. Remove the inner glass by pulling it carefully upwards.

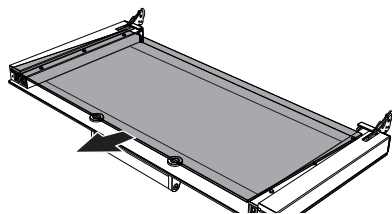

6. Clean the external glass pane and the panes removed previously. Use absorbent kitchen roll. In case of stubborn dirt, wash with a damp sponge and neutral detergent.

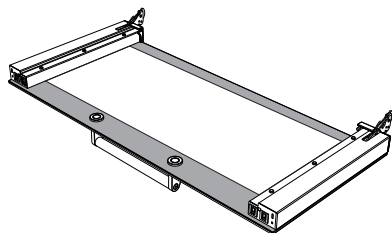

7. Once you have finished cleaning, reposition the inner glass.

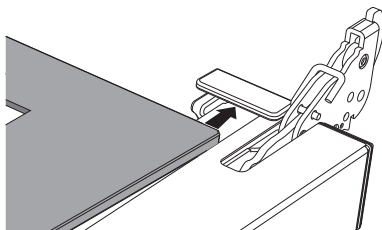

8. Remove the retaining clips from the hinges and position them in their seats on the door frame.

9. Replace the caps at the top of the door.

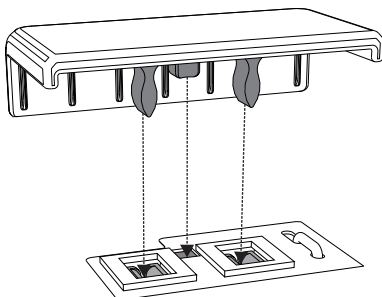

10. Close the door.



Swing door models

Cleaning the oven door is significantly facilitated as the internal glass pane can be opened.

1. Open the door
2. Pull the upper and lower caps to remove them.

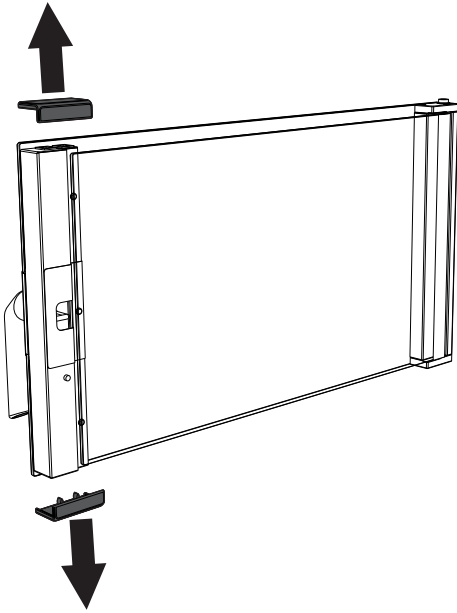

3. Open the internal glass pane.

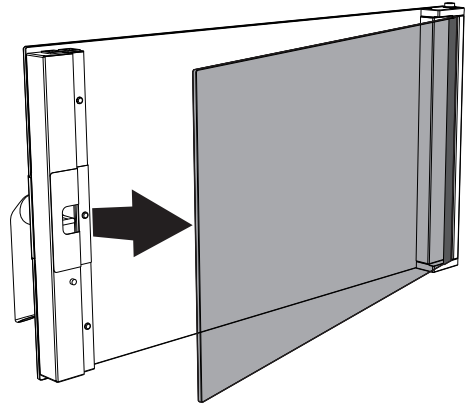

4. Clean both the interior and exterior of the glass panes. Use absorbent kitchen roll. In case of stubborn dirt, wash with a damp sponge and neutral detergent.

EN



Cleaning and maintenance

5. After cleaning, close the internal glass again.

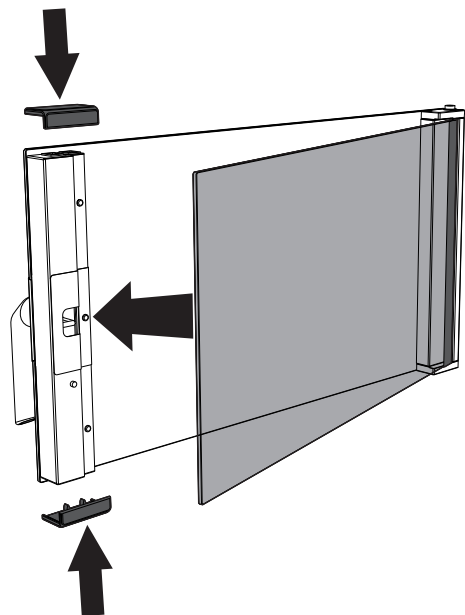

6. Reposition the upper and lower caps, applying light pressure.

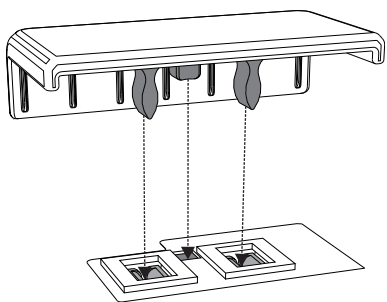

4.4 Cleaning the oven cavity

Cleaning the oven cavity

In order to keep your oven in the best possible condition, clean it regularly after letting it cool down.

Avoid letting food residue dry inside the oven cavity, as this could damage the surfaces.

Take out all removable parts before cleaning.

For easier cleaning, we recommend removing:

- The door
- Tray support frames
- The gasket.



In the event you are using specific cleaning products, we recommend running the oven at maximum temperature for 15-20 minutes in order to eliminate any residue.



For easier cleaning, remove the door.



Removing the tray support frames

Removing the tray support frames enables the sides to be cleaned more easily.

1. Unscrew the fastening ring nuts completely.

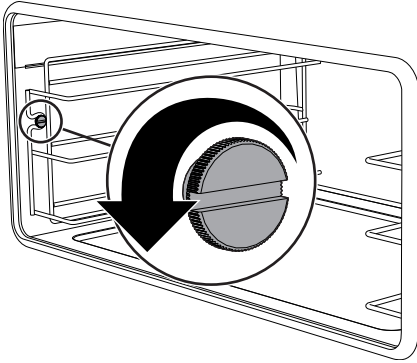

2. Remove the tray support frames from their seats on the deflector and remove them from the oven.
3. When you have finished cleaning, reposition the tray support frames inside the oven and fasten them with the fastening ring nuts.

4.5 Extraordinary maintenance

Removing the door gasket

To remove the gasket:

- Pull the gasket outwards to remove it.

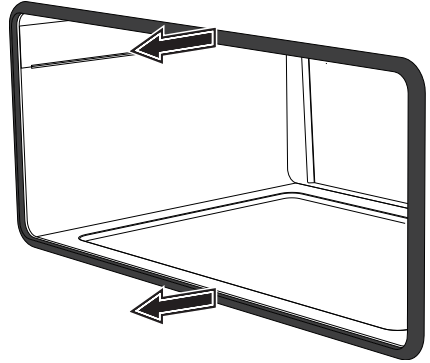

To refit the gasket:

- Position the gasket in the groove at the front, then press carefully down on it until it adheres to the face of the appliance.

Gasket maintenance tips

The gasket should be soft and elastic.

- To keep the gasket clean, use a non-abrasive sponge and wash with lukewarm water.



Cleaning and maintenance

Replacing the internal light bulb



Live parts
Danger of electrocution

- Disconnect the appliance.



The oven is fitted with two 40W light bulbs.

1. Completely remove all accessories from inside the oven.
2. Remove the rack/tray support frames.
3. Remove the bulb cover using a tool (e.g. a screwdriver).



Take care not to scratch the surface of the oven cavity.

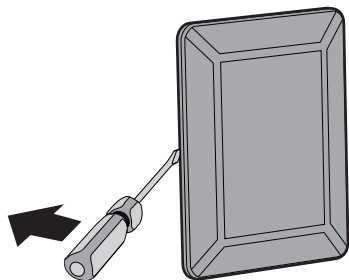

4. Slide out and remove the light bulb.

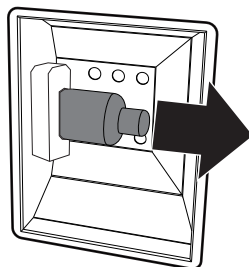

Do not touch the halogen light bulb directly with your fingers, but wrap it in insulating material.

5. Fit the new light bulb.
6. Refit the cover. Ensure the moulded part of the glass (A) is facing the door.

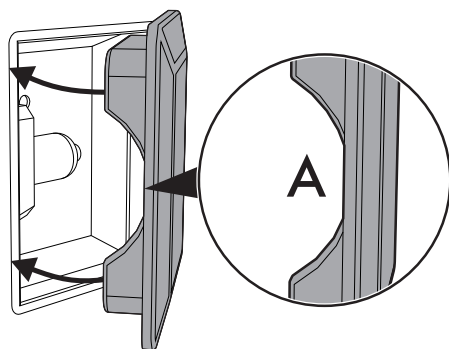

7. Press the cover completely down so that it attaches perfectly to the bulb support.



4.6 If the appliance is not working properly

Problem	Possible solution
The appliance is not working properly	<ul style="list-style-type: none"> • The timer knob is positioned on 0. • The plug is not correctly inserted in the socket. • The electrical system is damaged or not working properly. • The fuses have blown or the circuit breakers are off/have tripped.
The appliance cooks food either too slowly or too quickly	<ul style="list-style-type: none"> • The temperature setting is incorrect.
Moisture forms inside the oven and on foods	<ul style="list-style-type: none"> • Food is being left in the oven for too long after cooking. Do not leave it in the oven for more than 15-20 minutes after the end of the cooking time.

This product meets current safety regulations for electrical appliances. To prevent safety hazards for users, all technical inspections or repairs must be carried out by qualified personnel.



If the appliance is not working properly, before calling Technical Support, ensure that the procedures listed above have been performed.

Regular Maintenance

- The appliance must be checked over thoroughly by a qualified technician on a regular basis (at least once a year).
- Any maintenance work must only be performed by a qualified technician.
- Before performing any kind of maintenance, disconnect the appliance from the mains and wait for it to cool down if it has recently been used.



Cleaning and maintenance

5 Installation

5.1 Electrical connection



The terminal indicated by symbol  links up parts that are normally earthed. Connect the appliances appropriately using this terminal in order to make sure that they are equipotential.



If the phase voltage drops below $190V\sim$, the performance of the oven may suffer, not due to the product itself.

General information

Check the grid characteristics against the data indicated on the plate. The identification plate bearing the technical data, serial number and brand name is visibly positioned on the appliance. Do not remove this plate for any reason.

Perform the ground connection using a wire that is 20 mm longer than the other wires.

The appliance is provided with a five-core H07RN-F cable ($5 \times 1.5 \text{ mm}^2$ referring to the cross section of the internal conductor).

Connection modes:

- **220-240 V 1N~**

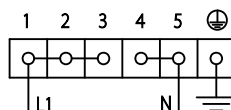

- **3 x 4 mm² three-core cable.**

- **220-240 V 3~**

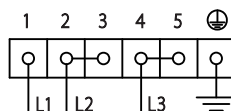

- **4 x 4 mm² four-core cable.**

- **380-415 V 2N~**

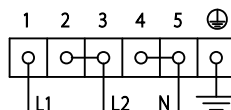

- **4 x 2.5 mm² four-core cable.**

- **380-415 V 3N~**

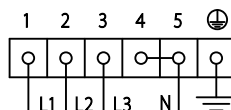

- **5 x 1.5 mm² five-core cable.**



The values indicated above refer to the cross-section of the internal conductor.



Fixed connection

Fit the power line with an omnipolar circuit breaker in compliance with installation regulations.

The circuit breaker should be located near the appliance and in an easily reachable position.

Connection with plug and socket

Check that the plug (not supplied) and power socket are compatible and of adequate capacity for the maximum current draw of the appliance.

Avoid using adapters and shunts as these could cause overheating and a risk of burns.

Cable replacement



**Power voltage
Danger of electrocution**

- Disconnect the mains power supply.

1. Use a flat-head screwdriver to unhook and lift the cover to access the terminal board.

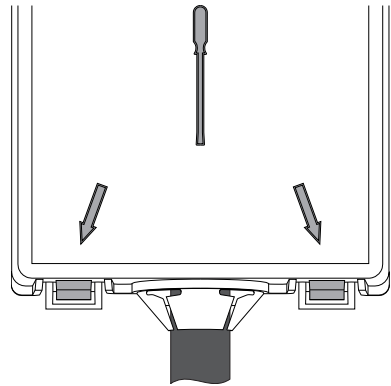

2. Replace the cable.
3. Make sure that the cables follow the best route in order to avoid any contact with the appliance.



Installation

5.2 Water connection



Improper use
Risk of damage to the appliance

- If the water pipe is new or has not been used for a long time, before making the connection, let the water flow to ensure that it is clear and free from impurities.
- The inlet pressure should be between 50 kPa min. and 500 kPa max.

Connect the water inlet socket on the back of the appliance to a water socket with a threaded $\frac{3}{4}$ " opening.

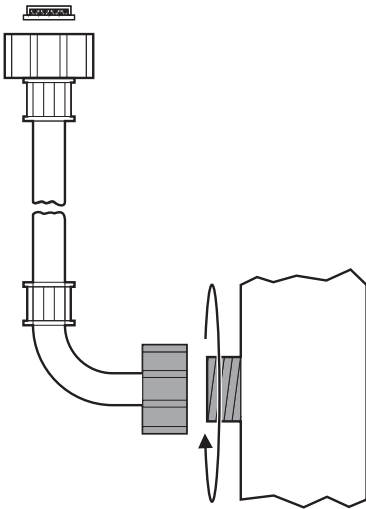

5.3 Positioning



Heavy appliance
Crushing hazard

- Position the appliance with the aid of a second person.



Pressure on the open door
Risk of damage to the appliance

- Never use the open door to lever the appliance into place when fitting.
- Avoid exerting too much pressure on the oven door when open.



Heat production during appliance operation
Risk of fire

- Veneers, adhesives or plastic coatings on adjacent furniture should be temperature-resistant (no less than 90°C).



Improper installation
Risk of injury

- The appliance support base should not exceed a height of 1.60 m from the floor.

Levelling

Level the appliance on the ground using the adjustable feet. The foot has a range of 10 mm.



Steam outlet pipe

Depending on the model, there are exhaust flues on the back of the appliance to release the steam produced during cooking.

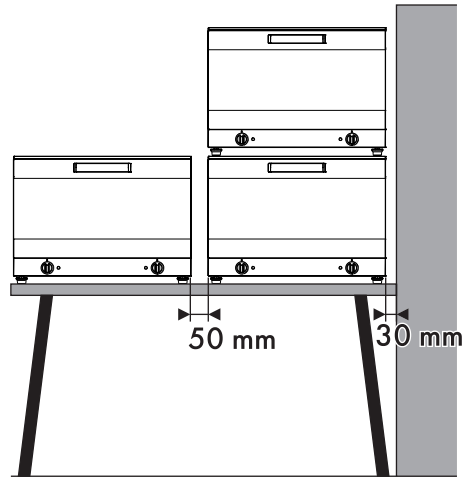
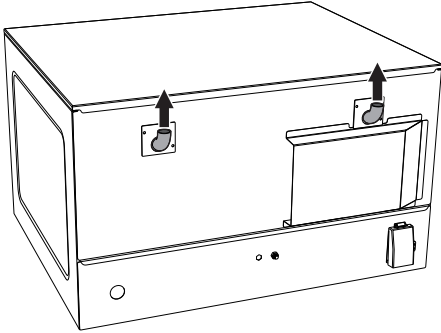

EN



These must be left free of any obstruction. Avoid crushing and contact with any walls.

Multiple installations



Weight: Kg 60

Place the appliance at a distance of at least 50 mm from any back wall and at 30 mm from any side wall. Keep a minimum distance of 50 mm between appliances if multiple appliances are installed alongside each other.

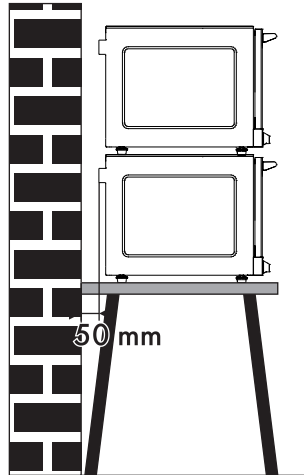

Do not install the appliance on the floor.



The appliance must be installed on a worktop.



Installation



High food temperature Danger of burns

- For safety reasons, **DO NOT** position the uppermost tray at a height above 160 cm.
- If necessary, **it is MANDATORY to apply the supplied adhesive label at the height indicated in the figure below.**

