



## FW482 Integrated in-column freezer

### Features

- 4 star rating
- Storage compartments: 4
- 1 ice cube tray
- Reversible doors
- Control system: Mechanical

### Technical specification

- Noise efficiency class: C
- Fixed hinges
- Freezing capacity: 8kg/24h
- Total useable capacity: 95L net
- Noise level: 38dBA
- Climate class: ST-N
- Left/ Right hinged door: Right
- Max storage time (power failure): 11
- Number of compressors: 1
- Power supply: 13A
- Rated power: 120W
- Refrigerant quantity: 54g
- Refrigerant type: R600a
- UK plug
- Voltage/frequency: 220-240/50

### Energy

- Energy consumption per annum: 221kW.h
- Energy rating: F

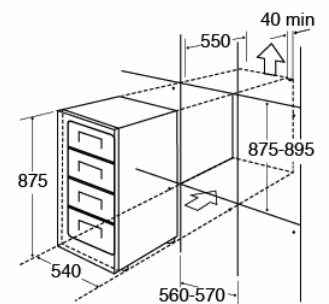

⇒ = airflow